

Hot Water Heater

QUALITY AUSTRALIAN MADE BOILERS

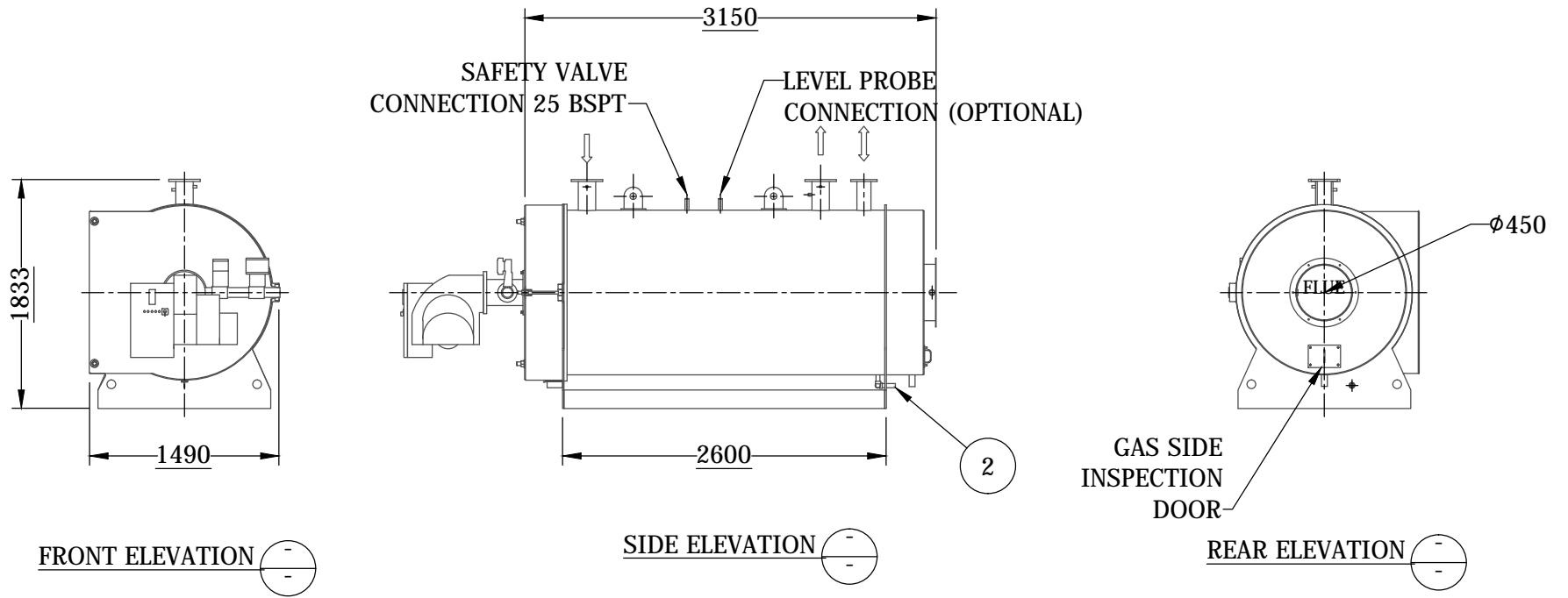
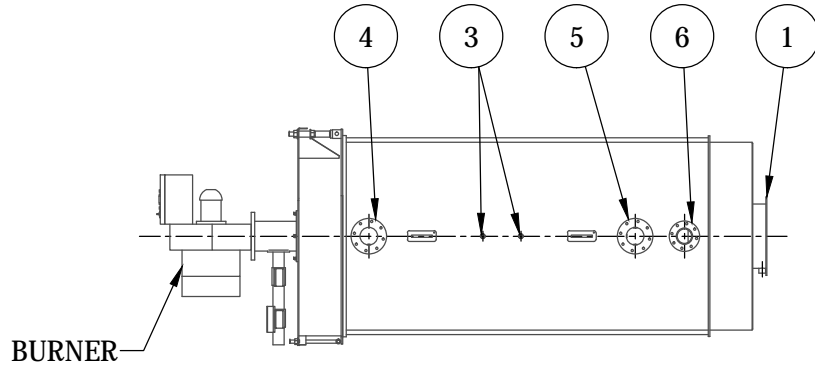

MAXIMUM WORKING PRESSURE STANDARD UNITS = 500 kpa
 MAXIMUM WORKING WATER TEMPERATURE STANDARD UNITS <90°C
 DESIGN CODE STANDARD UNITS = AS1210 (sect 3.3.2)
 SPECIFICATIONS SUBJECT TO CHANGE WITHOUT NOTICE.

WATER FLOW RATE kg/sec	WATER PRESSURE DROP kPa	$\Delta T 15^{\circ}\text{C}$	19.94
			2.94

ITEM	QTY	SIZE	DESCRIPTION
6	1	80 NB	VENT
5	1	125 NB	OUTLET
4	1	125 NB	INLET
3	2	25 NB	SAFETY VALVE
2	1	25 NB	DRAIN
1	1	450mm	FLUE BORE

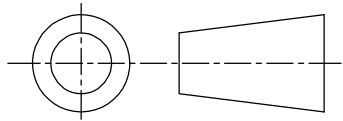

DRAWN TO AS1100:
DO NOT SCALE:
DIMENSIONS
IN MILLIMETERS:



CONSOLIDATED FIRE & STEAM
 32 Research Drive
 CROYDON SOUTH
 Victoria, Australia, 3136
 Ph: +61 (03) 8761 6677
 Web: www.confas.com.au

Notice: These drawings are the property of CF&S Pty. Ltd.
 These drawings and specifications may not be reproduced, copied
 or used as the basis for the manufacture or sale without written
 permission from CF&S Pty. Ltd.

©
Copyright 2005

TITLE: REVERSE FIRE BOILER
1250 kW

SIZE:
A4