

# Hot Water Heater

QUALITY AUSTRALIAN MADE BOILERS

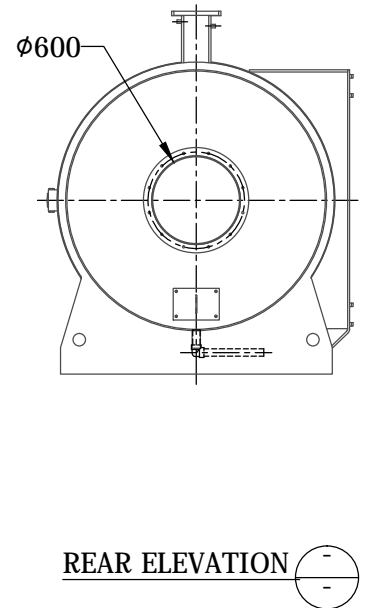
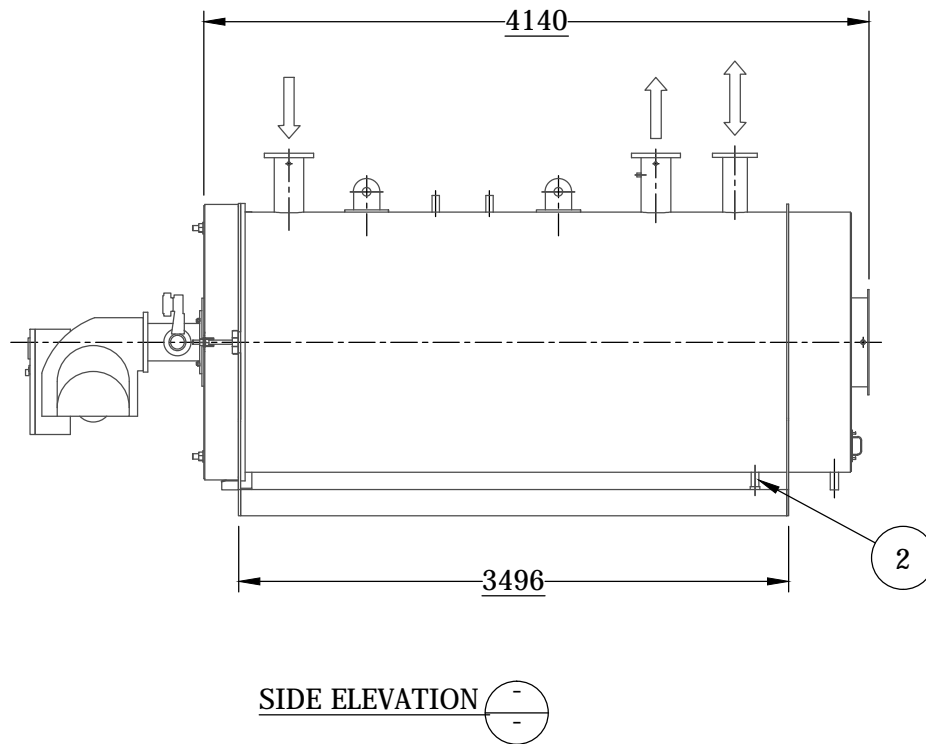
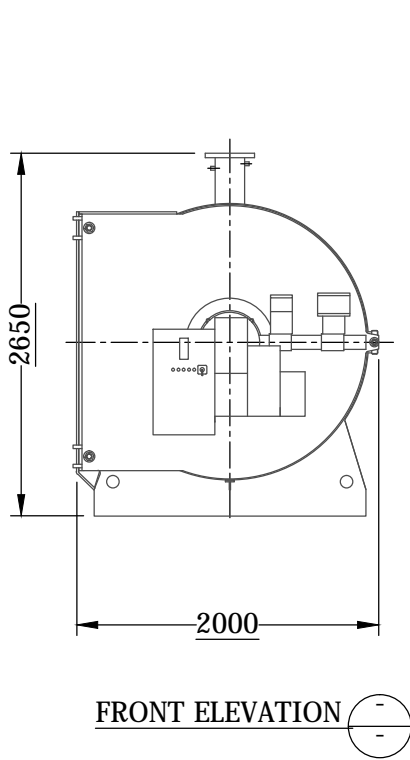
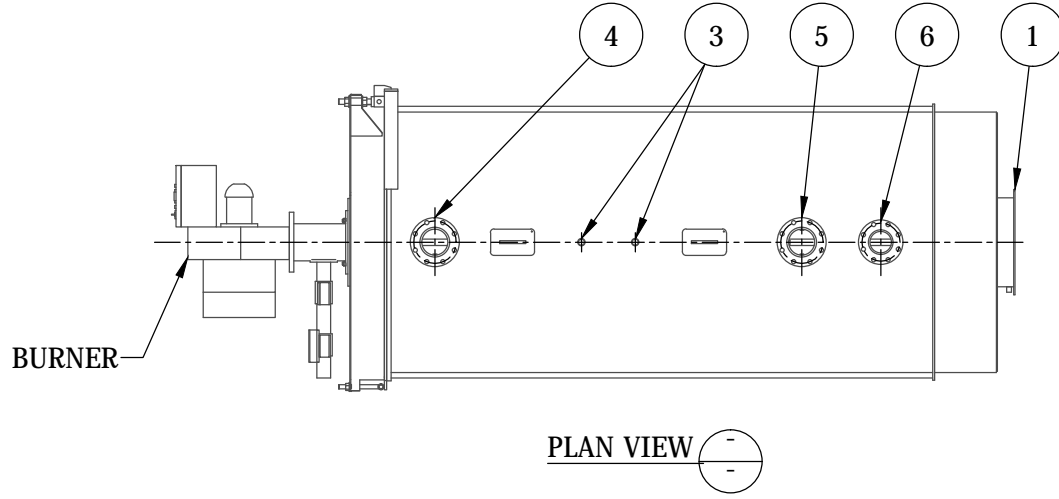

MAXIMUM WORKING PRESSURE STANDARD UNITS = 500 kpa  
 MAXIMUM WORKING WATER TEMPERATURE STANDARD UNITS <90°C  
 DESIGN CODE STANDARD UNITS = AS1210 (sect 3.3.2)  
 SPECIFICATIONS SUBJECT TO CHANGE WITHOUT NOTICE.

WATER FLOW RATE kg/sec	WATER PRESSURE DROP kPa	ΔT15°C	47.87
			4.90

ITEM	QTY	SIZE	DESCRIPTION
6	1	150 NB	VENT
5	1	200 NB	OUTLET
4	1	200 NB	INLET
3	2	32 NB	SAFETY VALVE
2	1	32 NB	DRAIN
1	1	600mm	FLUE BORE

PARTS LIST

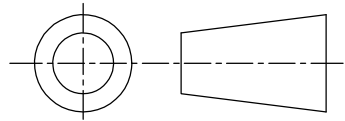

DRAWN TO AS1100:  
DO NOT SCALE:  
DIMENSIONS  
IN MILLIMETERS:



CONSOLIDATED FIRE & STEAM  
 32 Research Drive  
 CROYDON SOUTH  
 Victoria, Australia, 3136  
 Ph: +61 (03) 8761 6677  
 Web: www.confas.com.au

Notice: These drawings are the property of CF&S Pty. Ltd.  
 These drawings and specifications may not be reproduced, copied  
 or used as the basis for the manufacture or sale without written  
 permission from CF&S Pty. Ltd.

©  
Copyright 2005

TITLE: REVERSE FIRE BOILER  
3000 kW

SIZE:  
A4