

# Vertical Tubeless Boilers

QUALITY AUSTRALIAN MADE BOILERS

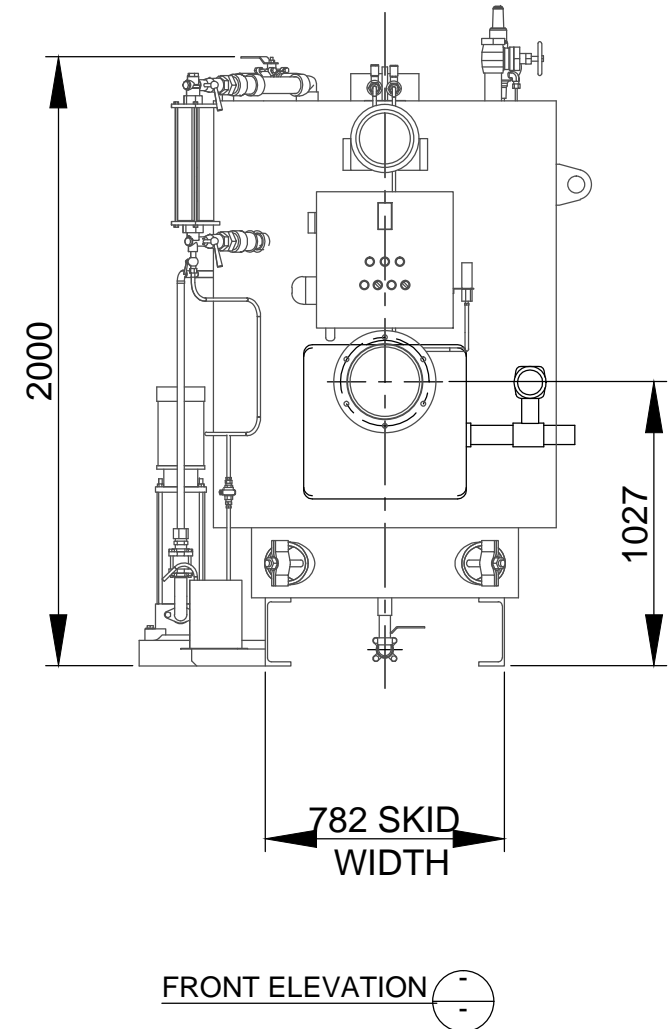
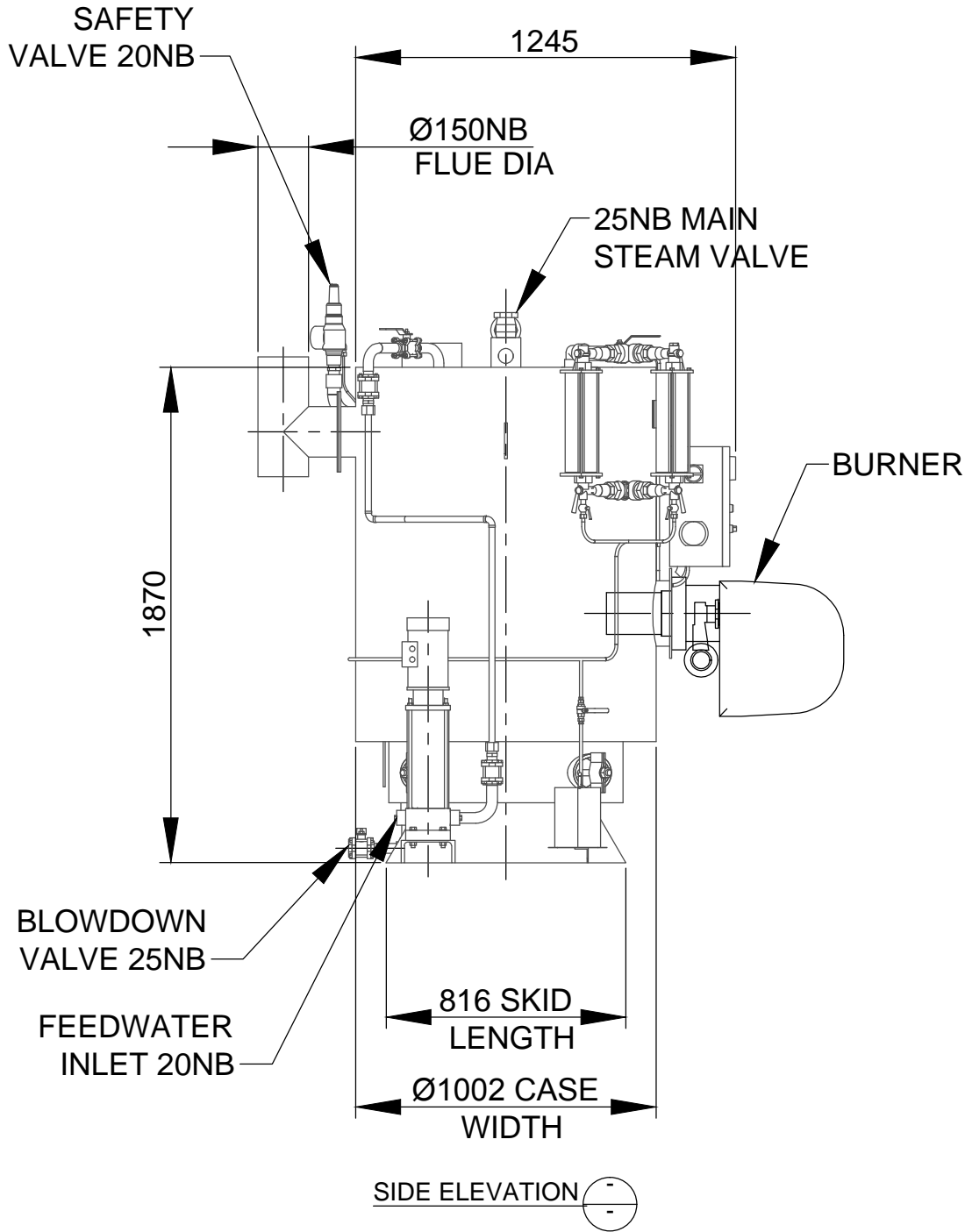

**NOTE:**  
Dimensions shown are approximate only and can be changed without notice.

**SPECIFICATIONS:**  
OUTPUT CAPACITY = 150kW  
EVAPORATION F&A 100°C kg/hr = 240  
INPUT - mJ/hr = 675  
HEATING SURFACE (sq mtr) = 5.5

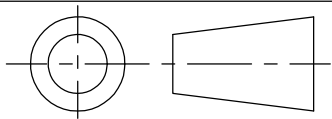

CONSOLIDATED FIRE & STEAM  
32 Research Drive  
CROYDON SOUTH  
Victoria, Australia, 3136  
Ph: +61 (03) 8761 6677  
Web: www.confas.com.au

DRAWN TO AS1100:  
DO NOT SCALE:  
DIMENSIONS  
IN MILLIMETERS:

Notice: These drawings are the property of CF&S Pty. Ltd. These drawings and specifications may not be reproduced, copied or used as the basis for the manufacture or sale without written permission from CF&S Pty. Ltd.

©  
Copyright 2005

TITLE: GENERAL DIMENSIONS  
VT150 VERTICAL TUBELESS STEAM BOILER

SIZE:  
A4