

Vertical Tubeless Boilers

QUALITY AUSTRALIAN MADE BOILERS

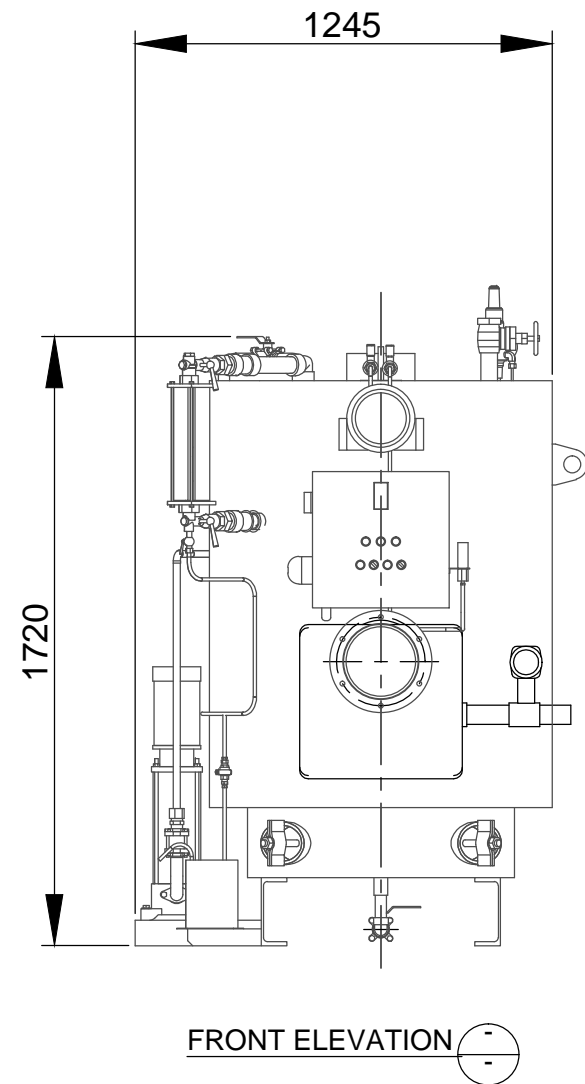
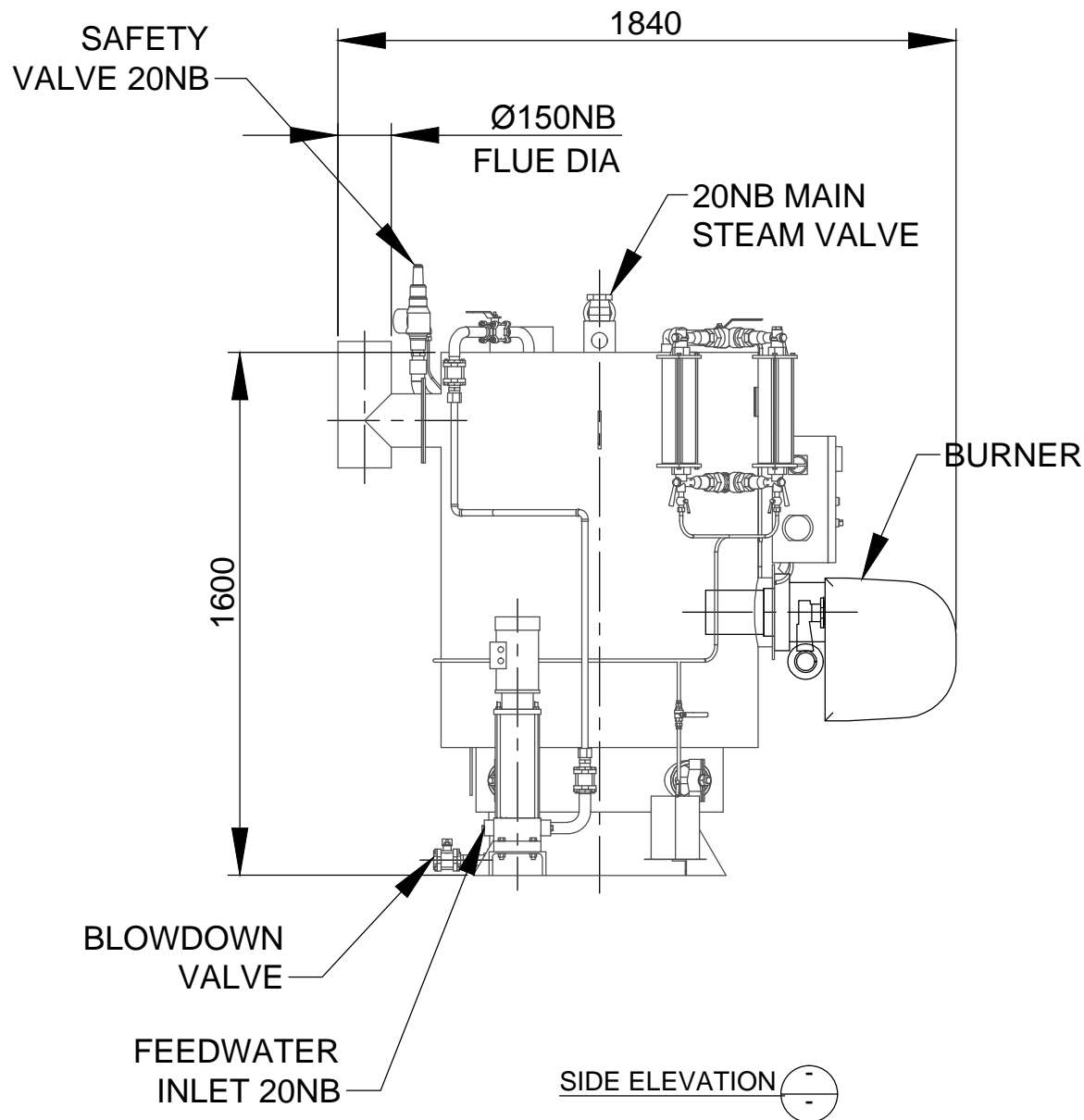

NOTE:
Dimensions shown are approximate only and can be changed without notice.

SPECIFICATIONS:
OUTPUT CAPACITY = 100kW
EVAPORATION F&A 100°C kg/hr = 160
INPUT - mJ/hr = 450
NOMINAL WATER CONTENT = 425 litres

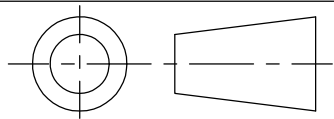

DRAWN TO AS1100:
DO NOT SCALE:
DIMENSIONS
IN MILLIMETERS:



CONSOLIDATED FIRE & STEAM
32 Research Drive
CROYDON SOUTH
Victoria, Australia, 3136
Ph: +61 (03) 8761 6677
Web: www.confas.com.au

Notice: These drawings are the property of CF&S Pty. Ltd. These drawings and specifications may not be reproduced, copied or used as the basis for the manufacture or sale without written permission from CF&S Pty. Ltd.

©
Copyright 2005

TITLE: GENERAL DIMENSIONS
VT100 VERTICAL TUBELESS STEAM BOILER

SIZE:
A4